

REMA RMG hydraulic jacks



Properties

- The desired height can easily be adjusted by a spindle.
- Protection against overload by overpressure valve.
- Can only be used between -20 ° C and 60 ° C.
- Do not use in an aggressive environment (alkalis, acids, etc.).
- Not suitable for continuous supporting the load.
- Suitable for horizontal use, pump must then sit on the underside of the pump.

Norm:

- EN12100-1/2, EN13157

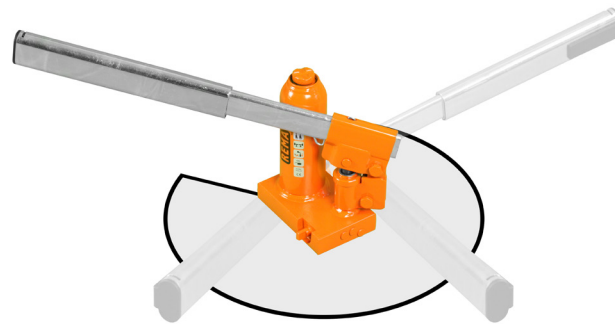
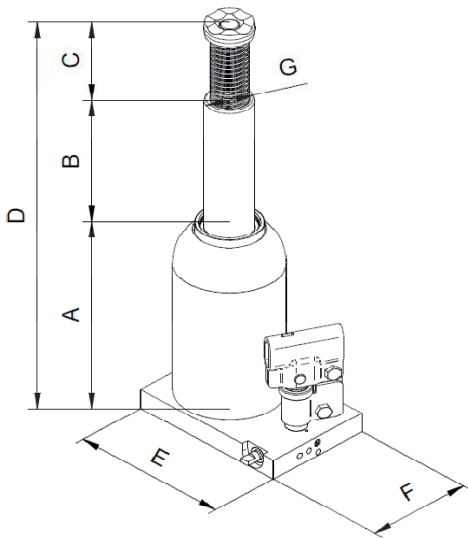

Type	WLL (kg)	A (mm)	B (mm)	C (mm)	D (mm)	E x F (mm)	G (mm)	Weight (kg)	ProductId
RMG-2	2.000	168	105	65	338	116 x 75	24	3.6	2760020
RMG-3	3.000	168	105	65	338	116 X 75	24	3.7	2760030
RMG-5	5000	212	150	75	437	125 X 75	29	4.5	2760050
RMG-10	10.000	219	150	75	444	144 X 90	37.2	6.4	2760100
RMG-15	15.000	228	150	75	453	164 X 110	44.5	8.5	2760150
RMG-20	20.000	234	150	75	459	172 X 120	50.9	10.6	2760200
RMG-30	30.000	242	150	75	467	196 X 144	57.6	15.5	2760300
RMG-50	50.000	260	140	-	400	214 X 165	80	28	2760500
RMG-100	100.000	300	150	-	450	333 X 296	110	87	2761000